

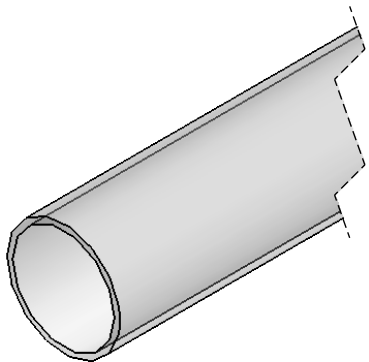

REVISION HISTORY			
REV.	DESCRIPTION	DATE	DRAWN BY
1	ORIGINAL PRINT	6/24/2026	J. TAN

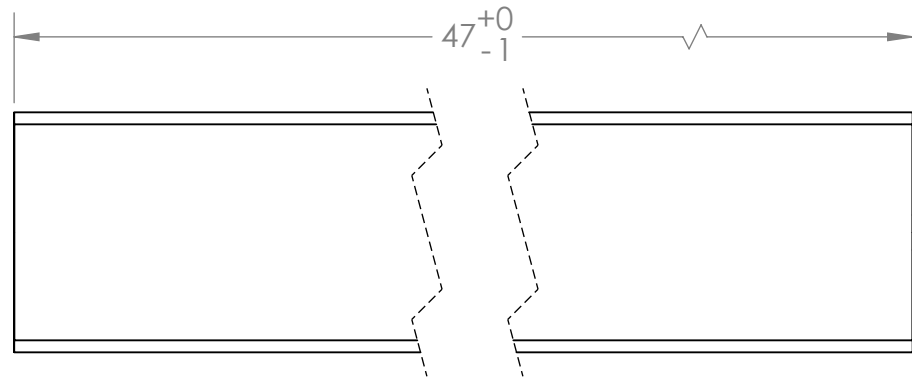
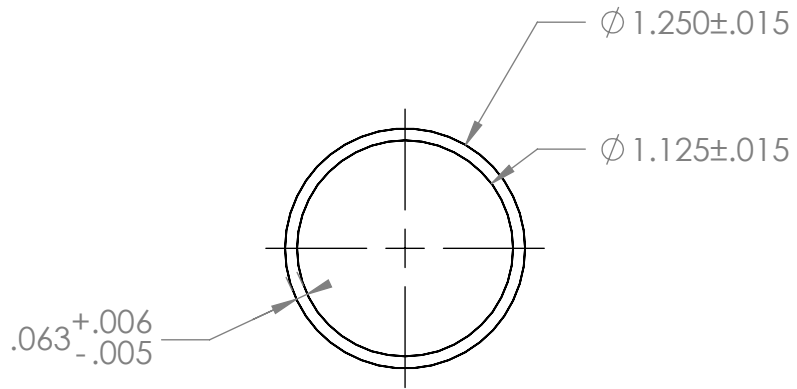

\*\*\* SEE CAD FOR ADDITIONAL TOOLPATH INFO\*\*\*

UNLESS OTHERWISE SPECIFIED:		COMMENTS:					
<b>DIMENSIONS ARE IN INCHES</b>		DUAL DIMENSIONS ARE IN MILLIMETERS.					
TOLERANCES: FRACTIONAL $\pm 1/16$ ANGULAR: MACH $\pm 1^\circ$ ANGULAR: BEND $\pm 5^\circ$ ONE PLACE DECIMAL $\pm 0.1$ TWO PLACE DECIMAL $\pm 0.01$ THREE PLACE DECIMAL $\pm 0.005$ FOUR PLACE DECIMAL $\pm 0.0005$		BREAK ALL SHARP EDGES.		TITLE: POLYCARBONATE TUBING, 1.125IN ID, 1.250IN OD, 47IN LONG			
MATERIAL CLEAR POLYCARBONATE		CHECKED	NAME NM	DATE 6/25/26	SIZE <b>A</b>	DWG. NO. am-5752	REV 1
FINISH DEBURRED		ENG APPR.			SCALE: 1:1		
DO NOT SCALE DRAWING		MFG APPR.			SHEET 1 OF 1		
		Q.A.					